



better together



HIGH-EFFICIENCY  
SUBMERSIBLE ELECTRIC PUMPS  
WITH CUTTING SYSTEM

# CHOPPER

UNIQA®

zenit.com

EN

# Chopper Series

The ultimate solution to clogging problems of pumps and pipes in solid waste sewage lifting plants

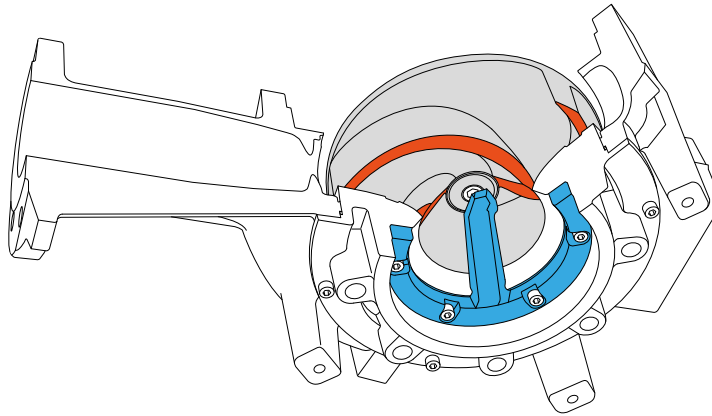

In wastewater treatment plants, more often than not, a **high amount solid waste**, even of large size, tends to build up inside the collection tanks, potentially **blocking the impeller** and **clogging up the pipes** making the lifting station almost ineffective.

When this occurs at a time when there is a large influx of water into the tank, the blocking of the pump become a serious issue that can lead to overflowing and compromise safety.



The use of filtering grids is not an effective solution because, in the presence of heavily loaded water, **constant monitoring** and **frequent removal** of the collected solid waste is needed.

The necessary periodic cleaning requires the intervention of specialised personnel and shutting down the system for the entire duration of the operations, with consequent increase in running costs.



The different nature of the **waste** present, which is fibrous but also contains plastic and metal, does not allow the use of normal shredding pumps because of their **small free passage**.

Furthermore, the limited flow rate that generally characterizes these models means that it takes a long time to empty the tank to the safety threshold.



## The Zenit solution

ZUG CP models with high-efficiency motors and hydraulic "Chopper" can expel any solid shreddable body present in the wastewater by exploiting an effective cutting system

The heart of the system consists of a robust **steel knife** with a sharp edge, skimming the blades of the **channel impeller** for cutting solid bodies of any shape and material. This prevents the impeller from blocking, but also avoids the build-up of residues in the pipe ensuring smooth operation of the system.

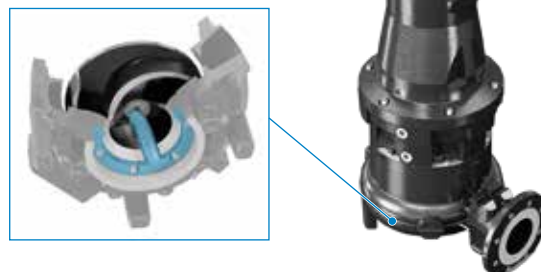

The **components** are designed using special three-dimensional fluid-dynamic modelling software.



Use of **innovative materials** which guarantee high resistance to mechanical stress and wear



**High-performance hydraulics** to secure the best operation even in the toughest working conditions

## A versatile range

The implemented constructive specifications and technical solutions make the **UNIQA Chopper** perfect for a wide range of civil and industrial applications



- Heavy-duty applications in civil wastewater treatment plants
- Pumping stations for wastewater containing solids
- Sewerage lifting systems



- Farms and livestock farm lifting systems
- Meat processing industry
- Fishing and canning industry



- Pulp and paper mill lifting systems
- Water recirculation in the textile and tanning industry
- Pumping of wastewater in industrial processes in general



How it is made

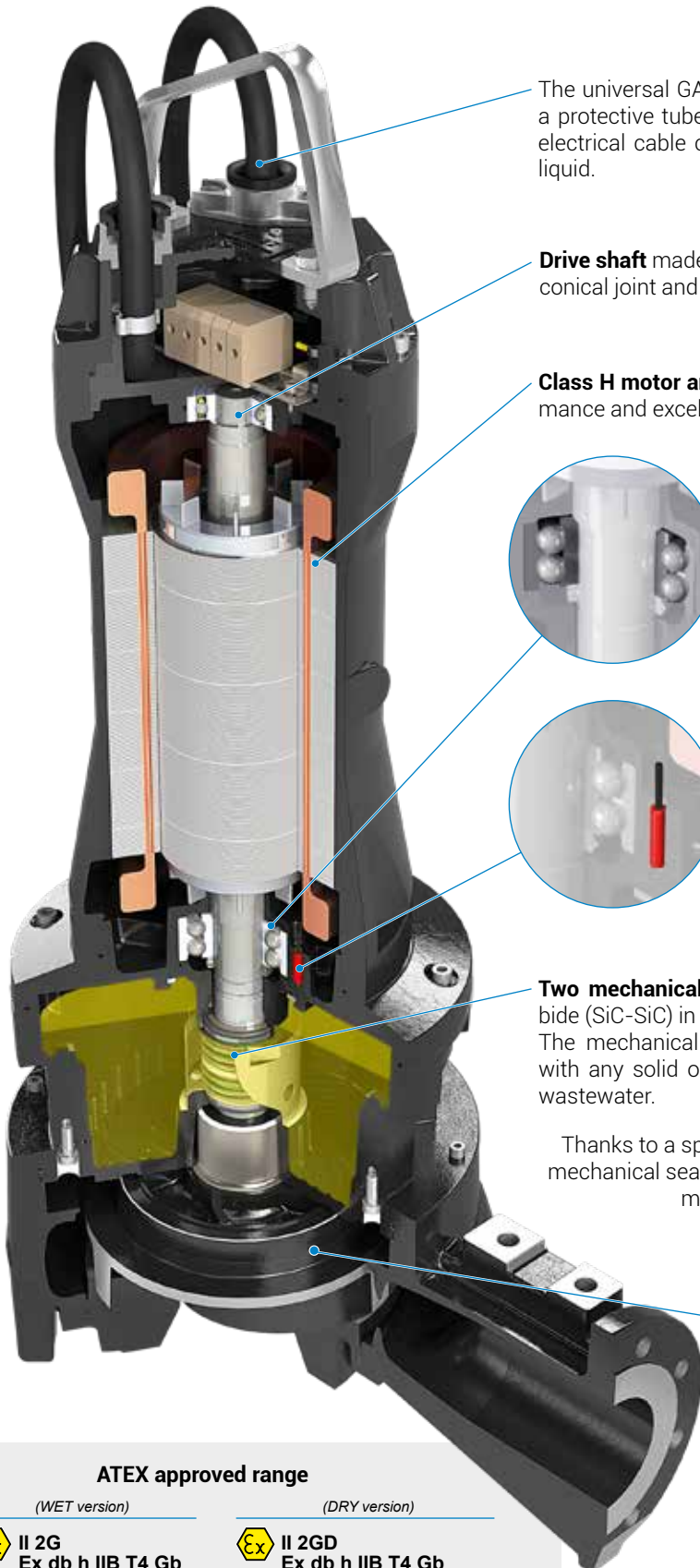

The universal GAS thread of the  **cable gland**  allows the attachment of a protective tube to reduce chemical and mechanical stresses on the electrical cable caused by turbulence or the aggressive nature of the liquid.

**Drive shaft**  made of AISI 431 steel with impeller coupling by means of a conical joint and skimming adjustment system.

**Class H motor and PREMIUM IE3 efficiency**  guaranteeing high performance and excellent energy efficiency.

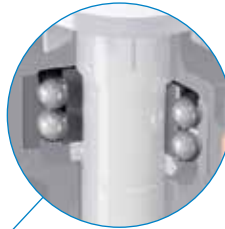

**Oversized bearings**  to ensure 100,000 hours of work.



One or more  **probes**  can be installed inside the motor, terminal box or oil chamber to signal the presence of water or moisture. Bearing vibration and temperature sensors.

**Two mechanical seals**  made of silicon carbide (SiC-SiC) in large oil chamber. The mechanical seals are never in contact with any solid or filaments contained in the wastewater.

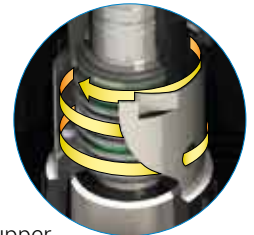

Thanks to a special component (*oil lifter*) the upper mechanical seal remains lubricated at all times, with more effective protection against wear



Standard  **chopper impeller**  made of *hard cast iron* with solid body shredding system.  **Hydraulic efficiency only -3/5% compared to a normal channel impeller**

**ATEX approved range**

(WET version)

 II 2G  
Ex db h IIB T4 Gb

(DRY version)

 II 2GD  
Ex db h IIB T4 Gb  
Ex h tb IIIC T135°C Db

## No-Lock cutting system

The innovative *No-Lock* system allows the cutting of shreddable solid bodies present in the wastewater, avoiding potential blockage.

Each chopper model is equipped with high-efficiency hydraulics which includes:

### • CHANNEL IMPELLER

With sharp-edged blades made of a new material we call **Hard cast iron**, which is stronger than the commonly used grey cast iron, with a hardness between 450 and 500 HB. Its composition is particularly complex and derives from the chemical union of several substances in precise proportions.

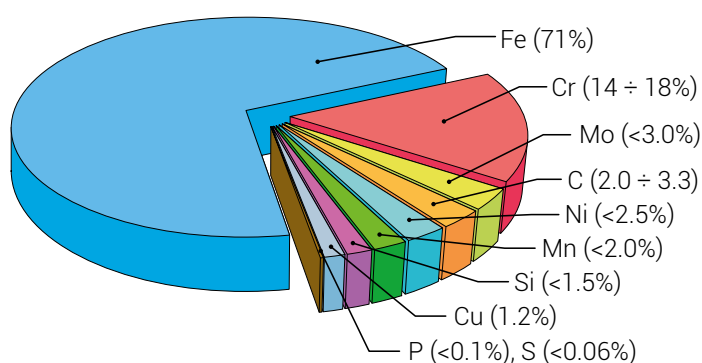

Name	<b>ASTM A532</b>
Class	<b>II</b>
Type	<b>B</b>
Designation	<b>15% Cr-Mo</b>



### • CUTTING SYSTEM

Formed by a knife skimming the impeller blades, made of AISI 431 steel. This material has a carbon content of about 0.12-0.22%. It is an excellent stainless steel with a hardness value of about 300 HB and a high shear strength.



In this configuration, the pump can **cut the solids and filaments** present in the effluent preventing potential **blockage** or clogging and is particularly resistant to the **corrosion**.

**Read the QR-code and watch the cutting test!**



## Cooling system

In **DRY version** models, the motor is cooled by a water and glycol mixture which circulates in a special closed circuit.

The coolant mixture is recirculated inside the pump by an **axial impeller** integral with the shaft and to the special design of the **double steel jacket** which ensures the necessary heat exchange between motor and external environment.

The continuous operation (**service class S1**) of the pump is also guaranteed in dry installations, in partially submerged conditions and in high-temperature environments.



## Performance

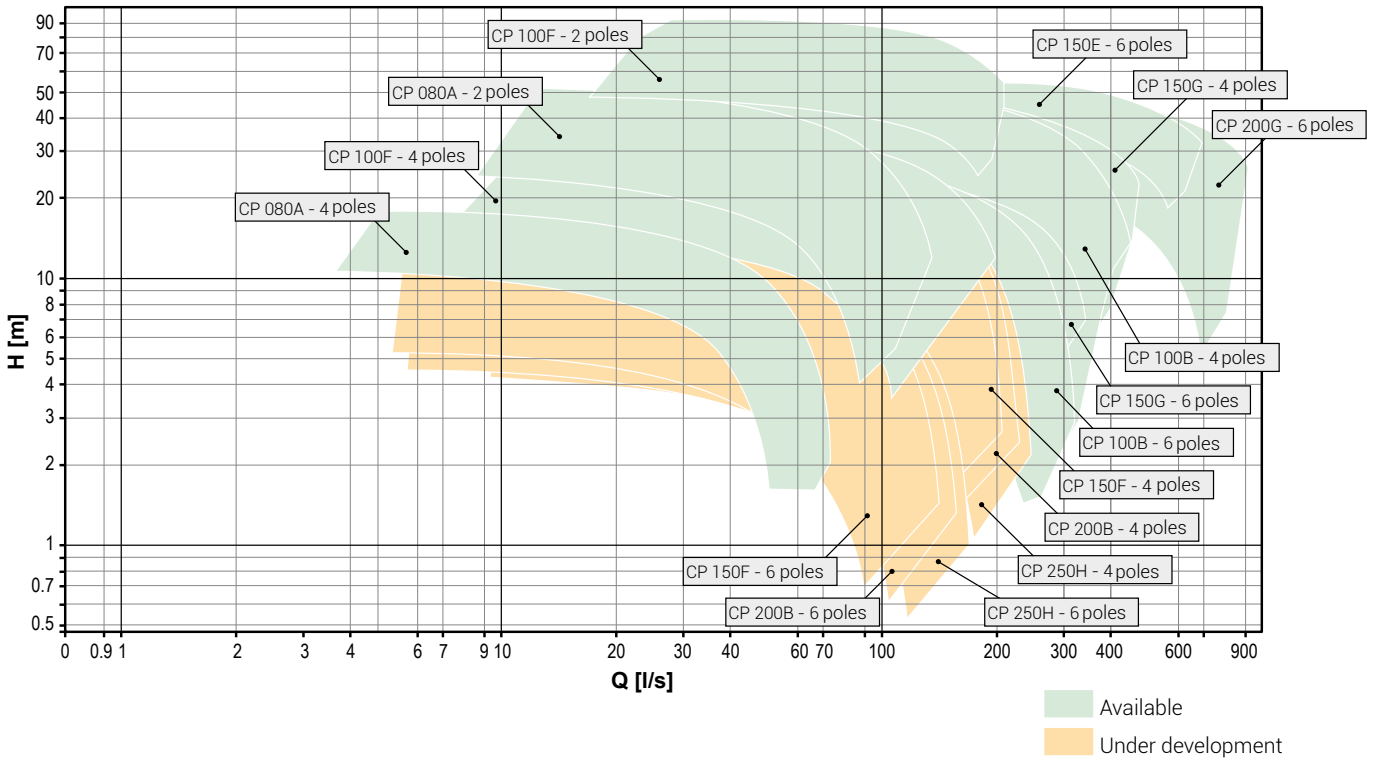

## Specifications

- 50 and 60Hz versions
- Thermal protections integrated in the stator
- Long-life bearings (up to 100,000 hours)
- Leakage monitoring system in sealed compartment (standard) and motor (optional)
- Two silicon carbide mechanical seals in large oil chamber
- Closed jacket cooling system with internal recirculation

## Specifications of use

Max. working temperature	40°C (60°C on request)
Liquid pH	6 - 14
Liquid viscosity	1 mm <sup>2</sup> /s
Liquid density	1 kg/dm <sup>3</sup>
Max. sound pressure level	<70 dB
Max. immersion depth	20 m
Max. start-ups per hour	20 [<10 kW] / 15 [>10kW]

## Materials

Motor casing	EN-GJL-250 cast iron
Impeller	Hard cast iron
Mechanical seals	2 made of silicon carbide (2SiC)
Screws	Stainless steel - Class A2-70
Standard gasket	Rubber - NBR
Drive shaft	Stainless steel - AISI 431
Cutter	Stainless steel - AISI 431
Painting	High-corrosion-resistant two-component epoxy

## Electrical and hydraulic data

**ZUG CP 080A**

2 poles	Power (kW)	4 - 11
	Delivery	DN80
	Suction	DN80
	Max. flow rate (l/s)	49
	Max. head (m)	40.5

4 poles	Power (kW)	1.1 - 1.5
	Delivery	DN80
	Suction	DN80
	Max. flow rate (l/s)	25
	Max. head (m)	10

**ZUG CP 100B**

4 poles	Power (kW)	11 - 45
	Delivery	DN100
	Suction	DN150
	Max. flow rate (l/s)	135
	Max. head (m)	40

6 poles	Power (kW)	4 - 13
	Delivery	DN100
	Suction	DN150
	Max. flow rate (l/s)	110
	Max. head (m)	75

**ZUG CP 100F**

2 poles	Power (kW)	22 - 45
	Delivery	DN100
	Suction	DN150
	Max. flow rate (l/s)	70
	Max. head (m)	75

4 poles	Power (kW)	3 - 15
	Delivery	DN100
	Suction	DN150
	Max. flow rate (l/s)	65.7
	Max. head (m)	25.5

**ZUG CP 150E**

6 poles	Power (kW)	45 - 75
	Delivery	DN150
	Suction	DN200
	Max. flow rate (l/s)	215
	Max. head (m)	41.3

**ZUG CP 150G**

4 poles	Power (kW)	11 - 45
	Delivery	DN150
	Suction	DN150
	Max. flow rate (l/s)	164
	Max. head (m)	39

6 poles	Power (kW)	4 - 13
	Delivery	DN150
	Suction	DN150
	Max. flow rate (l/s)	118
	Max. head (m)	18.4

**ZUG CP 200G**

6 poles	Power (kW)	22 - 75
	Delivery	DN200
	Suction	DN200
	Max. flow rate (l/s)	282
	Max. head (m)	40.1

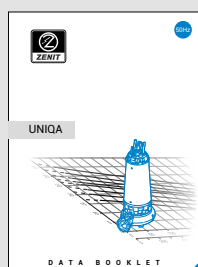

### Data Booklet

The technical data and hydraulic performances of the main **UNIQA** models are provided in the relative **Data Booklet** available for download from the website.



better together

The digital version of this catalogue is available for download at: [www.zenit.com](http://www.zenit.com)

The data provided are not binding.  
Zenit reserves the right to modify the product without advance notification.



For further information, visit [www.zenit.com](http://www.zenit.com)

Cod. 2904002091020000  
Rev. 3 - 01/01/2022